

SHOTGUN 2 0 2 1 PCP AIR RIFLES



www.interaselkon.com



ASELKON AŞ., which is one of the leading crane manufacturers in the machinery manufacturers sector, has been working on the crane industry since 2006. Our company, which operates on 45.000 m² open and 30.000 m² closed area is located in Konya, puts its signature under many successful products with its highly experienced, technically trained personnel.

By providing innovations to our sector with each passing day, we provide complete solutions by improving product and service quality together with high automation and flexibility concepts in order to provide better quality products and more comprehensive support.

Aselkon has already started to the projects of semi-automatic hunting arms under the scope of the law 2521 and 2019 defense arm industry.

Our company, who is paying attention to the customer satisfaction and adopting a principle of a sustainable quality, established his own test software and R&D laboratory in order to enable his customers an international quality standard.

R & D products are designed by our engineers, technical personnel and designers who constantly develop themselves.

The products that we design are manufactured according to all production procedures and processes by applying the latest technological machines and modern techniques in internationally accepted standards. Within the scope of project management, computer-aided design, simulation and design verification studies and prototype manufacturing are performed according to these results and the final product is decided.

The brands of Aselkon AŞ. is already demonstrate its quality and now became a worldwide known producer.

FUNCTIONING | STOCK DETAILS



- ① FUNCTIONING TEST
- ② CONDITIONS TEST
- ③ 3D & GUN CHECKS TEST
- ④ ACCURACY TEST
- ⑤ PRESSURE DROP TEST

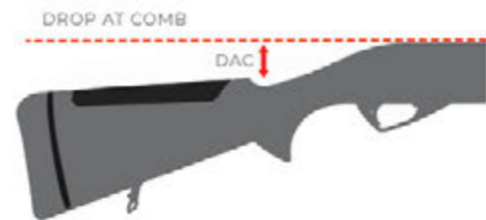

DAC is can be adjustable to 35-39 mm

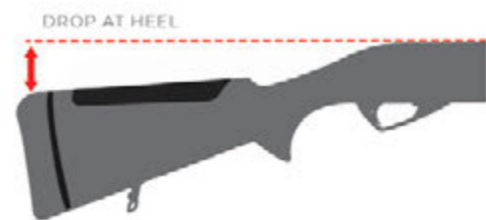

DAH is can be adjustable to 45-50-55-60 mm

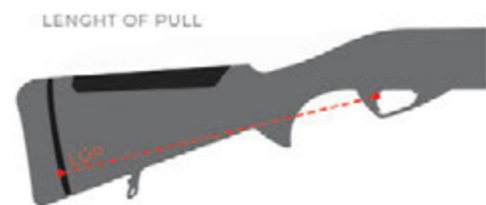

LOP is can be adjustable to -5, -10 mm



Shotgun

interarms

10-23

RedStone

24-35

Super
MAGNUM

36-41

TACTICAL

42-43

S4 MODELS
HYBRID

48-53

S3 MODELS
HYBRID

54-59

PCP Air Rifles

MX5

64-65

MX6

66-67

MX7

68-69

MX7-S

70-71

MX8

72-73

MX9

74-75

MX10

76-77

MX10-S

78-79

RX5

80-81

RX6

82-83



interarms

Shotguns

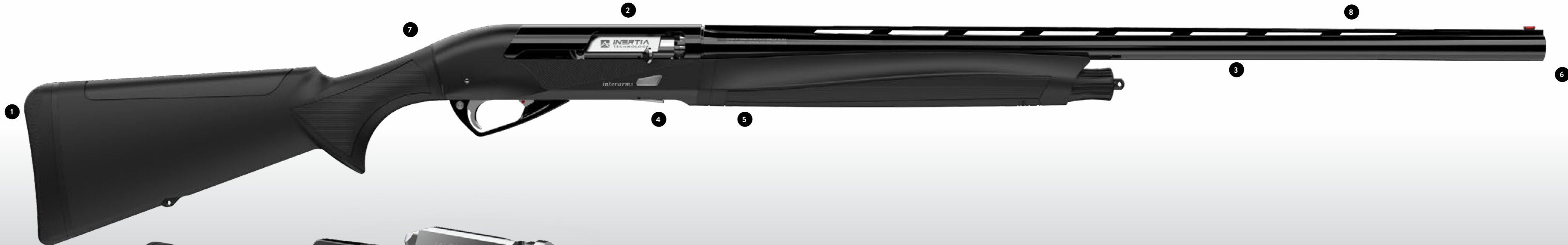

SWIVEL KIT



Our proprietary refinements to the ultra-reliable Bruno Civolani "floating bolt" action ensure the Inter Arms is able to quickly cycle even the lightest of 12 gauge loads. The Inter Arms's rotating bolt utilizes our unstoppable Inertia Technology Locking System to ensure positive bolt head lock-up to the breach under all conditions



1



INERTIA TECHNOLOGY

2

Our proprietary refinements to the ultra-reliable Bruno Civolani "floating bolt" action ensure the Inter Arms is able to quickly cycle even the lightest of 12 gauge loads. The Inter Arms's rotating bolt utilizes our unstoppable Inertia Technology Locking System to ensure positive bolt head lock-up to the breach under all conditions.



1500 BAR

3

Each Inter barrel is subjected to a proof test with 1500 BAR high pressure test cartridge before leaving our factory.



4

We engineered the interchangeable InterPro Chokes to maximize the constancy of shot placement through reduced friction that enhances load speeds.



5

The Inter Arms comes standard with our precision drilled Interbored barrel. The barrel is designed to shoot comfortably and pattern superbly with both light and heavy loads.

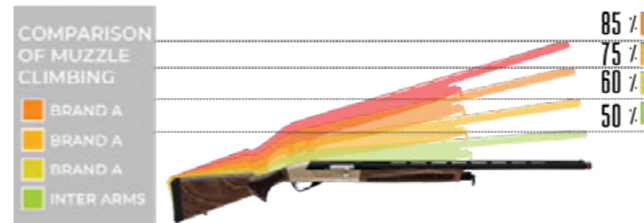

INTERPLUSCHOKE

6

We engineered the interchangeable InterPro Chokes to maximize the constancy of shot placement through reduced friction that enhances load speeds.



DROP & CAST ADJUSTMENT

7

INTERBORED BARREL

8

The Inter Arms comes standard with our precision drilled Interbored barrel. The barrel is designed to shoot comfortably and pattern superbly with both light and heavy loads.





interarms

the most
COMFORT POWER

INERTIA
TECHNOLOGY

1500
BAR

EASY
LOAD

INTER.
BALANCED

INTERPLUS CHOKE

INTERBORED BARREL

COMFORT
RECOIL

LUXURY
WOOD



INTER DARK BLACK



INTER BRONZE PURE



INTER SILVER





INTER EXTRA BLACK



INTER GRAY LIGHT



INTER MATTE BLACK



INTER BRONZE LIGHT



INTER SILVER LIGHT



INTER CAMO MAX5



**INTER BOTTOMLAND
BRONZE**



**INTER TIMBER
BRONZE**



INTER BOTTOMLAND



INTER TIMBER





elegant

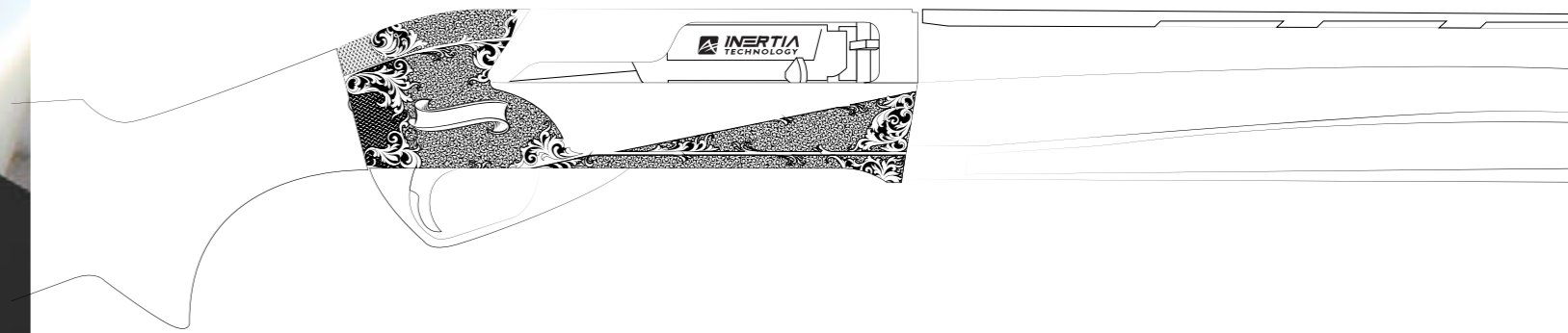

interarms



INTER ELEGANT SILVER BLACK



INTER ELEGANT BLACK



INTER ELEGANT SILVER



INTER ELEGANT BRONZE



INTER ELEGANT SEA GREEN



RedStone 

the most
COMFORT POWER

INERTIA
TECHNOLOGY

 **1500**
BAR

 **EASY**
LOAD

 **INTER.**
BALANCED

INTERPLUSCHOKE

INTERBOREDBARREL

 **COMFORT**
RECOIL

 **LUXURY**
WOOD



REDSTONE DARK BLACK



REDSTONE BRONZE PURE



REDSTONE SILVER



REDSTONE SILVER LIGHT



REDSTONE BRONZE LIGHT



REDSTONE MATTE BLACK



REDSTONE EXTRA BLACK



REDSTONE GRAY LIGHT





REDSTONE BOTTOMLAND



**REDSTONE
BOTTOMLAND BRONZE**



**REDSTONE
TIMBER BRONZE**



REDSTONE CAMO MAX5





REDSTONE ELEGANT SILVER BLACK



REDSTONE ELEGANT BLACK



REDSTONE ELEGANT SILVER



REDSTONE ELEGANT BRONZE



REDSTONE ELEGANT SEA GREEN



Super
MAGNUM

the most
COMFORT POWER





3,5" SUPER MAGNUM TIMBER



3,5" SUPER MAGNUM EXTRA BLACK



3,5" SUPER MAGNUM TIMBER BRONZE









3,5" SUPER MAGNUM CAMO MAX5

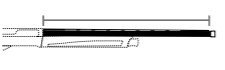

3,5" SUPER MAGNUM BOTTOMLAND BRONZE

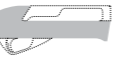

3,5" SUPER MAGNUM BOTTOMLAND

	 Gauge	 Chamber	 Mechanic	 Choke	 Barrel length	 Rib Size	 Stock length	 Drop at heel	 Drop at comb	 Handrail	 Stock	 Frame	 Epalet	 Magazine Capacity	 Safety	 Trigger	 Trigger Guard	 Weight	 Sight
3,5" Super Magnum Extra Black	12 - 3,5 inc	89 mm	Kinetic Drive inertial system semi-automatic rotating bolt	5 InterPro C-IC-M-IM-F	61-66-71-76 cm	8mm	340 mm	55±1 mm, 45-50-60 mm adjustable	37±1 mm	Synthetic	Synthetic	Aluminum Anodized Cerakote coating	Special polyurethane	Special polyurethane	Trigger safety	Trigger safety, Automatic locking system, Anti-repellent system	Special polyurethane	2.85± kg	Fiber optic sight
3,5" Super Magnum Bottomland	12 - 3,5 inc	89 mm	Kinetic Drive inertial system semi-automatic rotating bolt	5 InterPro C-IC-M-IM-F	61-66-71-76 cm	8mm	340 mm	55±1 mm, 45-50-60 mm adjustable	37±1 mm	Synthetic	Synthetic	Aluminum Anodized Cerakote coating	Special polyurethane	Special polyurethane	Trigger safety	Trigger safety, Automatic locking system, Anti-repellent system	Special polyurethane	2.85± kg	Fiber optic sight
3,5" Super Magnum Bottomland Bronze	12 - 3,5 inc	89 mm	Kinetic Drive inertial system semi-automatic rotating bolt	5 InterPro C-IC-M-IM-F	61-66-71-76 cm	8mm	340 mm	55±1 mm, 45-50-60 mm adjustable	37±1 mm	Synthetic	Synthetic	Aluminum Anodized Cerakote coating	Special polyurethane	Special polyurethane	Trigger safety	Trigger safety, Automatic locking system, Anti-repellent system	Special polyurethane	2.85± kg	Fiber optic sight
3,5" Super Magnum Timber	12 - 3,5 inc	89 mm	Kinetic Drive inertial system semi-automatic rotating bolt	5 InterPro C-IC-M-IM-F	61-66-71-76 cm	8mm	340 mm	55±1 mm, 45-50-60 mm adjustable	37±1 mm	Synthetic	Synthetic	Aluminum Anodized Cerakote coating	Special polyurethane	Special polyurethane	Trigger safety	Trigger safety, Automatic locking system, Anti-repellent system	Special polyurethane	2.85± kg	Fiber optic sight
3,5" Super Magnum Timber Bronze	12 - 3,5 inc	89 mm	Kinetic Drive inertial system semi-automatic rotating bolt	5 InterPro C-IC-M-IM-F	61-66-71-76 cm	8mm	340 mm	55±1 mm, 45-50-60 mm adjustable	37±1 mm	Synthetic	Synthetic	Aluminum Anodized Cerakote coating	Special polyurethane	Special polyurethane	Trigger safety	Trigger safety, Automatic locking system, Anti-repellent system	Special polyurethane	2.85± kg	Fiber optic sight
3,5" Super Magnum Camo Max5	12 - 3,5 inc	89 mm	Kinetic Drive inertial system semi-automatic rotating bolt	5 InterPro C-IC-M-IM-F	61-66-71-76 cm	8mm	340 mm	55±1 mm, 45-50-60 mm adjustable	37±1 mm	Synthetic	Synthetic	Aluminum Anodized Cerakote coating	Special polyurethane	Special polyurethane	Trigger safety	Trigger safety, Automatic locking system, Anti-repellent system	Special polyurethane	2.85± kg	Fiber optic sight



TACTICAL



TACTICAL

the most
COMFORT POWER

- INERTIA TECHNOLOGY
- 1500 BAR
- EASY LOAD
- INTER. BALANCED
- INTERPLUSCHOKE
- INTERBOREDBARREL
- COMFORT RECOIL



IT1-G-EXTRA BLACK



IT1-EXTRA BLACK



IT1-G-BOTTOMLAND BRONZ



IT1-G-BOTTOMLAND



IT1-GV-EXTRA BLACK



IT1-GV-BOTTOMLAND

	Gauge	Chamber	Mechanic	Choke	Barrel length	Rib Size	Stock length	Drop at heel	Drop at comb	Handrail	Stock	Frame	Epalet	Magazine Capacity	Safety	Trigger	Trigger Guard	Weight	Sight
IT1-G-Extra Black	12 - 3 inc	76 mm	Kinetic Drive inertial system semi-automatic rotating bolt	1 InterPro C	47-61-66 cm	Tactical	340 mm	55±1 mm, 45-50-60 mm adjustable	37±1 mm	Synthetic	Synthetic	Aluminum Anodized Cerakote coating	Special polyurethane	4+1x12/76	Trigger safety	Trigger safety, Automatic locking system, Anti-repellent system	Special polyurethane	2.85± kg	Fiber optic sight
IT1-Extra Black	12 - 3 inc	76 mm	Kinetic Drive inertial system semi-automatic rotating bolt	1 InterPro C	47-61-66 cm	Tactical	340 mm	55±1 mm, 45-50-60 mm adjustable	37±1 mm	Synthetic	Synthetic	Aluminum Anodized Cerakote coating	Special polyurethane	4+1x12/76	Trigger safety	Trigger safety, Automatic locking system, Anti-repellent system	Special polyurethane	2.85± kg	Fiber optic sight
IT1-G-Bottomland Bronz	12 - 3 inc	76 mm	Kinetic Drive inertial system semi-automatic rotating bolt	1 InterPro C	47-61-66 cm	Tactical	340 mm	55±1 mm, 45-50-60 mm adjustable	37±1 mm	Synthetic	Synthetic	Aluminum Anodized Cerakote coating	Special polyurethane	4+1x12/76	Trigger safety	Trigger safety, Automatic locking system, Anti-repellent system	Special polyurethane	2.85± kg	Fiber optic sight
IT1-G-Bottomland	12 - 3 inc	76 mm	Kinetic Drive inertial system semi-automatic rotating bolt	1 InterPro C	47-61-66 cm	Tactical	340 mm	55±1 mm, 45-50-60 mm adjustable	37±1 mm	Synthetic	Synthetic	Aluminum Anodized Cerakote coating	Special polyurethane	4+1x12/76	Trigger safety	Trigger safety, Automatic locking system, Anti-repellent system	Special polyurethane	2.85± kg	Fiber optic sight
IT1-Gv-Extra Black	12 - 3 inc	76 mm	Kinetic Drive inertial system semi-automatic rotating bolt	1 InterPro C	47-61-66 cm	8mm	340 mm	55±1 mm, 45-50-60 mm adjustable	37±1 mm	Synthetic	Synthetic	Aluminum Anodized Cerakote coating	Special polyurethane	4+1x12/76	Trigger safety	Trigger safety, Automatic locking system, Anti-repellent system	Special polyurethane	2.85± kg	Fiber optic sight
IT1-Gv-Bottomland	12 - 3 inc	76 mm	Kinetic Drive inertial system semi-automatic rotating bolt	1 InterPro C	47-61-66 cm	8mm	340 mm	55±1 mm, 45-50-60 mm adjustable	37±1 mm	Synthetic	Synthetic	Aluminum Anodized Cerakote coating	Special polyurethane	4+1x12/76	Trigger safety	Trigger safety, Automatic locking system, Anti-repellent system	Special polyurethane	2.85± kg	Fiber optic sight

S4 MODELS

HYBRID



the most
COMFORT POWER

INERTIA
TECHNOLOGY

1500
BAR

EASY
LOAD

INTER.
BALANCED

INTERPLUSCHOKE

INTERBORED BARREL

COMFORT
RECOIL



COMFORT RECOIL

Our proprietary refinements to the ultra-reliable Bruno Civolani "floating bolt" action ensure the Inter Arms is able to quickly cycle even the lightest of 12 gauge loads. The Inter Arms's rotating bolt utilizes our unstoppable Inertia Technology Locking System to ensure positive bolt head lock-up to the breach under all conditions



INERTIA TECHNOLOGY

Our proprietary refinements to the ultra-reliable Bruno Civolani "floating bolt" action ensure the Inter Arms is able to quickly cycle even the lightest of 12 gauge loads. The Inter Arms's rotating bolt utilizes our unstoppable Inertia Technology Locking System to ensure positive bolt head lock-up to the breach under all conditions.

1500 BAR

Each Inter barrel is subjected to a proof test with 1500 BAR high pressure test cartridge before leaving our factory.

EASY LOAD

We engineered the interchangeable InterPro Chokes to maximize the constancy of shot placement through reduced friction that enhances load speeds.

INTER. BALANCED

The Inter Arms comes standard with our precision drilled Interbored barrel. The barrel is designed to shoot comfortably and pattern superbly with both light and heavy loads.

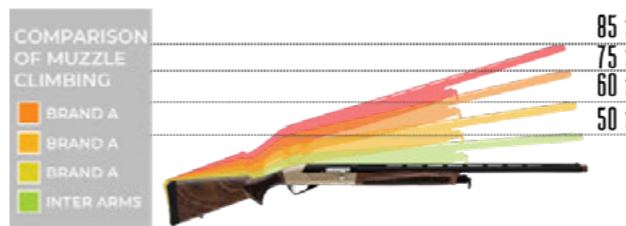

INTERPLUSCHOKE

We engineered the interchangeable InterPro Chokes to maximize the constancy of shot placement through reduced friction that enhances load speeds.

INTERBOREDBARREL

The Inter Arms comes standard with our precision drilled Interbored barrel. The barrel is designed to shoot comfortably and pattern superbly with both light and heavy loads.





S4-G-EXTRA BLACK



S4-GT-EXTRA BLACK



S4 EXTRA BLACK



S4-G TITANIUM



Gauge



Chamber

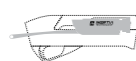

Mechanic



Choke

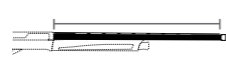

Barrel length



Rib Size



Stock length



Handrail



Stock



Frame



Epalet

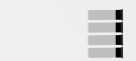

Magazine Capacity



Safety



Trigger



Trigger Guard



Weight



Sight

	Gauge	Chamber	Mechanic	Choke	Barrel length	Rib Size	Stock length
S4-G-Extra Black	12 - 3 inc	76 mm	Semi-Auto (Piston Driven Gas Operated)	1 InterPro C	47 cm	Tactical	Adjustable
S4-GT-Extra Black	12 - 3 inc	76 mm	Semi-Auto (Piston Driven Gas Operated)	1 InterPro C	47 cm	Tactical	Adjustable
S4 Extra Black	12 - 3 inc	76 mm	Semi-Auto (Piston Driven Gas Operated)	1 InterPro C	47 cm	Tactical	Adjustable
S4-G Titanium	12 - 3 inc	76 mm	Semi-Auto (Piston Driven Gas Operated)	1 InterPro C	47 cm	Tactical	Adjustable

Handrail	Stock	Frame	Epalet	Magazine Capacity	Safety	Trigger	Trigger Guard	Weight	Sight
Synthetic	Synthetic	Aluminum Anodized Cerakote coating	Special polyurethane	5+1 / 7+1 x 12/76	Trigger safety	Trigger safety, Automatic locking system, Anti-repellent system	Special polyurethane	3.55± kg	Tactical sight style
Synthetic	Synthetic	Aluminum Anodized Cerakote coating	Special polyurethane	5+1 / 7+1 x 12/76	Trigger safety	Trigger safety, Automatic locking system, Anti-repellent system	Special polyurethane	3.55± kg	Tactical sight style
Synthetic	Synthetic	Aluminum Anodized Cerakote coating	Special polyurethane	5+1 / 7+1 x 12/76	Trigger safety	Trigger safety, Automatic locking system, Anti-repellent system	Special polyurethane	3.55± kg	Tactical sight style
Synthetic	Synthetic	Aluminum Anodized Cerakote coating	Special polyurethane	5+1 / 7+1 x 12/76	Trigger safety	Trigger safety, Automatic locking system, Anti-repellent system	Special polyurethane	3.55± kg	Tactical sight style



S3 MODELS HYBRID



the most
COMFORT POWER

- INERTIA TECHNOLOGY
- 1500 BAR
- EASY LOAD
- INTER BALANCED
- INTERPLUSCHOKE
- INTERBORED BARREL
- COMFORT RECOIL



COMFORT RECOIL

Our proprietary refinements to the ultra-reliable Bruno Civolani "floating bolt" action ensure the Inter Arms is able to quickly cycle even the lightest of 12 gauge loads. The Inter Arms's rotating bolt utilizes our unstoppable Inertia Technology Locking System to ensure positive bolt head lock-up to the breach under all conditions

INERTIA TECHNOLOGY

Our proprietary refinements to the ultra-reliable Bruno Civolani "floating bolt" action ensure the Inter Arms is able to quickly cycle even the lightest of 12 gauge loads. The Inter Arms's rotating bolt utilizes our unstoppable Inertia Technology Locking System to ensure positive bolt head lock-up to the breach under all conditions.

EASY LOAD

We engineered the interchangeable InterPro Chokes to maximize the constancy of shot placement through reduced friction that enhances load speeds.

1500 BAR

Each Inter barrel is subjected to a proof test with 1500 BAR high pressure test cartridge before leaving our factory.

INTER. BALANCED

The Inter Arms comes standard with our precision drilled Interbored barrel. The barrel is designed to shoot comfortably and pattern superbly with both light and heavy loads.

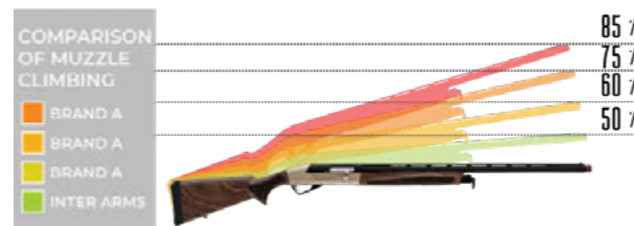

INTERBORED BARREL

The Inter Arms comes standard with our precision drilled Interbored barrel. The barrel is designed to shoot comfortably and pattern superbly with both light and heavy loads.

INTERPLUSCHOKE

We engineered the interchangeable InterPro Chokes to maximize the constancy of shot placement through reduced friction that enhances load speeds.





S3-EXTRA BLACK



S3-G-EXTRA BLACK



S3-GT-EXTRA BLACK



S3-G-TITANIUM



Gauge

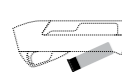

Chamber

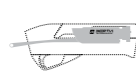

Mechanic



Choke

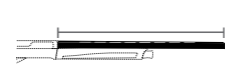

Barrel length



Rib Size



Stock length

	Gauge	Chamber	Mechanic	Choke	Barrel length	Rib Size	Stock length
S3-EXTRA BLACK	12 - 3 inc	76 mm	Tactical	1 InterPro C	47 cm	Tactical	Adjustable
S3-G-EXTRA BLACK	12 - 3 inc	76 mm	Tactical	1 InterPro C	47 cm	Tactical	Adjustable
S3-GT-EXTRA BLACK	12 - 3 inc	76 mm	Tactical	1 InterPro C	47 cm	Tactical	Adjustable
S3-G-TITANIUM	12 - 3 inc	76 mm	Tactical	1 InterPro C	47 cm	Tactical	Adjustable



Handrail



Stock



Frame



Epalet

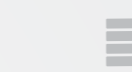

Magazine Capacity



Safety

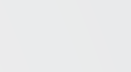

Trigger



Trigger Guard

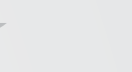

Weight



Sight

Handrail	Stock	Frame	Epalet	Magazine Capacity	Safety	Trigger	Trigger Guard	Weight	Sight
Synthetic	Synthetic	Aluminum Anodized Cerakote coating	Special polyurethane	5+1 / 7+1 x 12/76	Trigger safety	Trigger safety, Automatic locking system, Anti-repellent system	Special polyurethane	3.55± kg	Tactical sight style
Synthetic	Synthetic	Aluminum Anodized Cerakote coating	Special polyurethane	5+1 / 7+1 x 12/76	Trigger safety	Trigger safety, Automatic locking system, Anti-repellent system	Special polyurethane	3.55± kg	Tactical sight style
Synthetic	Synthetic	Aluminum Anodized Cerakote coating	Special polyurethane	5+1 / 7+1 x 12/76	Trigger safety	Trigger safety, Automatic locking system, Anti-repellent system	Special polyurethane	3.55± kg	Tactical sight style
Synthetic	Synthetic	Aluminum Anodized Cerakote coating	Special polyurethane	5+1 / 7+1 x 12/76	Trigger safety	Trigger safety, Automatic locking system, Anti-repellent system	Special polyurethane	3.55± kg	Tactical sight style

PCP Air Rifles





COMFORT RECOIL

It is a shock absorbing shoulder system made of a mixture of special polyurethane and rubber materials.

ADJUSTABLE TRIGGER

Setting the trigger distances according to the finger structure of each user; (right, left, up and down trigger setting) designed to make the trigger system.



ASELKON MANO METER



Pressure gauge showing the dry air pressure inside the tube without disturbing the visibility

SLIENCER

Pressure gauge showing the dry air pressure inside the tube without disturbing the visibility



PICATINNY 2mm

Setting the trigger distances according to the finger structure of each user; (right, left, up and down trigger setting) designed to make the trigger system.



COMFORT COMB

It is a cheek system obtained from special raw material mixtures in order to prevent slipping of the cheek during aiming and to ensure comfortable aiming while maintaining the face sensitivity.

ERGONOMIC GRIP

It is a pistol grip system designed from special materials for comfort and ease of grip.



INDEX MAGAZINE

It is a magazine system designed from special materials for automatic pellet scrolling after pellet filling.



MX5 JET BLACK

MX5

Side lever cocking system with manual locking system. Adjustable cheek piece soft rubber coated. Rubber grip for a better control and shooting feeling Precision rifled barrel special coated. Micro adjustable rear sight for both windage and elevation Truglo Special stainless black electsol coating.



Kinetic Energy is adjustable from
3 to 60 Joules



MX5 MATTE BLACK

Gauge	Muzzle Output Speed*	Energy	Magazine Capacity	Tube Volume	Filling Pressure	Number of Shots	Forearm Engraving	Total Length	Barrel Length	Weight	Binocular Rail	Replacement Magazine
4.5 mm / .177 cal	850/900 FPS	Joules 35	14	320 cc	200 bar	90 / 80 / 65	Turkish Walnut	1100 mm (43.30)	550mm (21.6)	3250 gr (7.16 lbs)	Yes	Yes
5.5 mm / .22 cal	850/970 FPS	Joules 52	12	320 cc	200 bar	90 / 80 / 65	Turkish Walnut	1100 mm (43.30)	550mm (21.6)	3250 gr (7.16 lbs)	Yes	Yes
6.35 mm / .25 cal	840/890 FPS	Joules 62	10	320 cc	200 bar	90 / 80 / 65	Turkish Walnut	1100 mm (43.30)	550mm (21.6)	3250 gr (7.16 lbs)	Yes	Yes



MX6 MATTE BLACK

MX6

Side lever cocking system with manual locking system. Adjustable cheek piece soft rubber coated. Rubber grip for a better control and shooting feeling Precision rifled barrel special coated. Micro adjustable rear sight for both windage and elevation Truglo Special stainless black electsol coating.



Kinetic Energy is adjustable from
3 to 60 Joules



MX6 JET BLACK

Gauge	Muzzle Output Speed*	Energy	Magazine Capacity	Tube Volume	Filling Pressure	Number of Shots	Forearm Engraving	Total Length	Barrel Length	Weight	Binocular Rail	Replacement Magazine
4.5 mm / .177 cal	850/900 FPS	Joules 35	14	320 cc	200 bar	90 / 80 / 65	Turkish Walnut	1100 mm (43.30)	550mm (21.6)	3250 gr (7.16 lbs)	Yes	Yes
5.5 mm / .22 cal	870/950 FPS	Joules 52	12	320 cc	200 bar	90 / 80 / 65	Turkish Walnut	1100 mm (43.30)	550mm (21.6)	3250 gr (7.16 lbs)	Yes	Yes
6.35 mm / .25 cal	840/890 FPS	Joules 62	10	320 cc	200 bar	90 / 80 / 65	Turkish Walnut	1100 mm (43.30)	550mm (21.6)	3250 gr (7.16 lbs)	Yes	Yes



MX7 BLACK

MX7

Side lever cocking system with manual locking system. Adjustable cheek piece soft rubber coated. Rubber grip for a better control and shooting feeling Precision rifled barrel special coated. Micro adjustable rear sight for both windage and elevation Truglo Special stainless black elecsol coating.



Kinetic Energy is adjustable from
3 to 60 Joules



MX7 MAX5



MX7 WOOD

Gauge	Muzzle Output Speed*	Energy	Magazine Capacity	Tube Volume	Filling Pressure	Number of Shots	Forearm Engraving	Total Length	Barrel Length	Weight	Binocular Rail	Replacement Magazine
4.5 mm / .177cal	850/1100 FPS	Joules 25	14	320cc	200bar	80-70-55	Turkish Walnut Synthetic	850mm	550mm	2750gr	Yes	Yes
5.5 mm / .22 cal	850/900 FPS	Joules 49	12	320cc	200bar	80-70-55	Turkish Nut Synthetic	850mm	550mm	2750gr	Yes	Yes
6.35 mm / .25 cal	840/890 FPS	Joules 62	10	320cc	200bar	80-70-55	Turkish Nut Synthetic	850mm	550mm	2750gr	Yes	Yes



MX7-S MAX5

MX7-S

Side lever cocking system with manual locking system. Adjustable cheek piece soft rubber coated. Rubber grip for a better control and shooting feeling Precision rifled barrel special coated. Micro adjustable rear sight for both windage and elevation Truglo Special stainless black electsol coating.



Kinetic Energy is adjustable from
3 to 60 Joules



MX7-S BLACK



MX7-S WOOD



Gauge



Muzzle Output Speed*



Energy



Magazine Capacity



Tube Volume



Filling Pressure



Number of Shots



Forearm Engraving

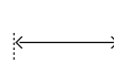

Total Length



Barrel Length



Weight



Binocular Rail



Replacement Magazine

4.5 mm / .177cal

830/880 FPS

Joules 22

14

275cc

200bar

80-70-55

Turkish Walnut Synthetic

650mm

450mm

2600gr

Yes

Yes

5.5 mm / .22 cal

830/870 FPS

Joules 41

12

275cc

200bar

80-70-55

Turkish Nut Synthetic

650mm

450mm

2600gr

Yes

Yes

6.35 mm / .25 cal

800/850 FPS

Joules 54

10

275cc

200bar

80-70-55

Turkish Nut Synthetic

650mm

450mm

2600gr

Yes

Yes



MX8 BLACK

MX8













Side lever cocking system with manual locking system. Adjustable cheek piece soft rubber coated. Rubber grip for a better control and shooting feeling Precision rifled barrel special coated. Micro adjustable rear sight for both windage and elevation Truglo Special stainless black electsol coating.



Kinetic Energy is adjustable from
3 to 60 Joules

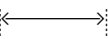

MX8 MAX5

 Gauge	 Muzzle Output Speed*	 Energy	 Magazine Capacity	 Tube Volume	 Filling Pressure	 Number of Shots	 Forearm Engraving	 Total Length	 Barrel Length	 Weight	 Binocular Rail	 Replacement Magazine
4.5 mm / .177cal	800/1100 FPS	Joules 35	14	500cc	250bar	90-80-65	Synthetic	950mm	550mm	3250gr	Yes	Yes
5.5 mm / .22 cal	870/950 FPS	Joules 54	12	500cc	250bar	90-80-65	Synthetic	950mm	550mm	3250gr	Yes	Yes
6.35 mm / .25 cal	840/900 FPS	Joules 62	10	500cc	250bar	90-80-65	Synthetic	950mm	550mm	3250gr	Yes	Yes



MX9 WOOD

MX9

Side lever cocking system with manual locking system. Adjustable cheek piece soft rubber coated. Rubber grip for a better control and shooting feeling Precision rifled barrel special coated. Micro adjustable rear sight for both windage and elevation Truglo Special stainless black electsol coating.



Kinetic Energy is adjustable from
3 to 60 Joules



Gauge



Muzzle Output Speed*



Energy



Magazine Capacity



Tube Volume



Filling Pressure



Number of Shots



Forearm Engraving



Total Length



Barrel Length



Weight



Binocular Rail



Replacement Magazine

4.5 mm / .177cal

800/1100 FPS

Joules 35

14

500cc

250bar

90-80-65

Turkish Walnut Synthetic

1100mm

550mm

3750gr

Yes

Yes

5.5 mm / .22 cal

870/950 FPS

Joules 54

12

500cc

250bar

90-80-65

Turkish Nut Synthetic

1100mm

550mm

3750gr

Yes

Yes

6.35 mm / .25 cal

840/900 FPS

Joules 62

10

500cc

250bar

90-80-65

Turkish Nut Synthetic

1100mm

550mm

3750gr

Yes

Yes



MX10 BLACK

MX10

Side lever cocking system with manual locking system. Adjustable cheek piece soft rubber coated. Rubber grip for a better control and shooting feeling Precision rifled barrel special coated. Micro adjustable rear sight for both windage and elevation Truglo Special stainless black electrol coating.



Kinetic Energy is adjustable from
3 to 60 Joules



MX10 MAX5



MX10 WOOD



Gauge



Muzzle Output Speed*



Energy



Magazine Capacity



Tube Volume



Filling Pressure



Number of Shots



Forearm Engraving



Total Length



Barrel Length



Weight



Binocular Rail



Replacement Magazine

4.5 mm / .177cal

830/950 FPS

Joules 22

14

275cc

200bar

80-70-55

Turkish Walnut Synthetic

850mm

450mm

2850gr

Yes

Yes

5.5 mm / .22 cal

830/950 FPS

Joules 49

12

275cc

200bar

80-70-55

Turkish Nut Synthetic

850mm

450mm

2850gr

Yes

Yes

6.35 mm / .25 cal

800/850 FPS

Joules 54

10

275cc

200bar

80-70-55

Turkish Nut Synthetic

850mm

450mm

2850gr

Yes

Yes



MX10-S BLACK

MX10-S

Side lever cocking system with manual locking system. Adjustable cheek piece soft rubber coated. Rubber grip for a better control and shooting feeling Precision rifled barrel special coated. Micro adjustable rear sight for both windage and elevation Truglo Special stainless black electrol coating.



Kinetic Energy is adjustable from
3 to 60 Joules



MX10-S MAX5



MX10-S WOOD

Gauge	Muzzle Output Speed*	Energy	Magazine Capacity	Tube Volume	Filling Pressure	Number of Shots	Forearm Engraving	Total Length	Barrel Length	Weight	Binocular Rail	Replacement Magazine
4.5 mm / .177cal	830/890FPS	Joules 22	14	275cc	200bar	80-70-55	Turkish Walnut Synthetic	850mm	450mm	2850gr	Yes	Yes
5.5 mm / .22 cal	830/870 FPS	Joules 49	12	275cc	200bar	80-70-55	Turkish Nut Synthetic	850mm	450mm	2850gr	Yes	Yes
6.35 mm / .25 cal	830/870 FPS	Joules 54	10	275cc	200bar	80-70-55	Turkish Nut Synthetic	850mm	450mm	2850gr	Yes	Yes



PCP RAVELLO RX5

RAVELLO RX5

Side lever cocking system with manual locking system. Adjustable cheek piece soft rubber coated. Rubber grip for a better control and shooting feeling Precision rifled barrel special coated. Micro adjustable rear sight for both windage and elevation Truglo Special stainless black electsol coating.



Kinetic Energy is adjustable from
3 to 60 Joules



 Gauge	 Muzzle Output Speed*	 Energy	 Magazine Capacity	 Tube Volume	 Filling Pressure	 Number of Shots	 Forearm Engraving	 Total Length	 Barrel Length	 Weight	 Binocular Rail	 Replacement Magazine
4.5 mm / .177 cal	850/900 FPS	Joules 35	14	320 cc	200 bar	90 / 80 / 65	Turkish Walnut	1100 mm (43.30)	550mm (21.6)	3250 gr (7.16 lbs)	Yes	Yes
5.5 mm / .22 cal	850/970 FPS	Joules 52	12	320 cc	200 bar	90 / 80 / 65	Turkish Walnut	1100 mm (43.30)	550mm (21.6)	3250 gr (7.16 lbs)	Yes	Yes
6.35 mm / .25 cal	840/890 FPS	Joules 62	10	320 cc	200 bar	90 / 80 / 65	Turkish Walnut	1100 mm (43.30)	550mm (21.6)	3250 gr (7.16 lbs)	Yes	Yes



PCP RAVELLO RX6

RAVELLO RX6

Side lever cocking system with manual locking system. Adjustable cheek piece soft rubber coated. Rubber grip for a better control and shooting feeling Precision rifled barrel special coated. Micro adjustable rear sight for both windage and elevation Truglo Special stainless black electsol coating.



Kinetic Energy is adjustable from
3 to 60 Joules



Gauge



Muzzle Output Speed*



Energy



Magazine Capacity



Tube Volume



Filling Pressure



Number of Shots



Forearm Engraving



Total Length



Barrel Length



Weight



Binocular Rail



Replacement Magazine

4.5 mm / .177cal

850/900 FPS

Joules 35

14

550 cc

250 bar

110/100/85

Turkish Walnut

1100 mm
(43.30)550mm
(21.6)

3750 gr

Yes

Yes

5.5 mm / .22 cal

870/950 FPS

Joules 54

12

550 cc

250 bar

110/100/85

Turkish Walnut

1100 mm
(43.30)550mm
(21.6)

3750 gr

Yes

Yes

6.35 mm / .25 cal

840/890 FPS

Joules 62

10

550 cc

250 bar

110/100/85

Turkish Walnut

1100 mm
(43.30)550mm
(21.6)

3750 gr

Yes

Yes





aselkon 🔍



www.interaselkon.com



2 0 2 1



Büyükkayacık O.S.B. 516 Nolu Sk. No:19-19/1

Telephone : +90 332 342 26 12 / +90 332 342 40 04 / Mobile: +90 532 136 08 96

Mobile Export : +90 553 407 00 86

E-Mail : info@aselkon.com.tr / exportexecutive@aselkon.com.tr

www.aselkon.com.tr